



# SOBA (Green/White) MECA (Blue/White)

## FLOAT LEVEL REGULATOR

For automatic regulation with several devices



### USE

VR – Emptying / Filling

### SIZE

Height: 170 mm – Diameter: 80 mm

### DIFFERENTIAL ANGLE

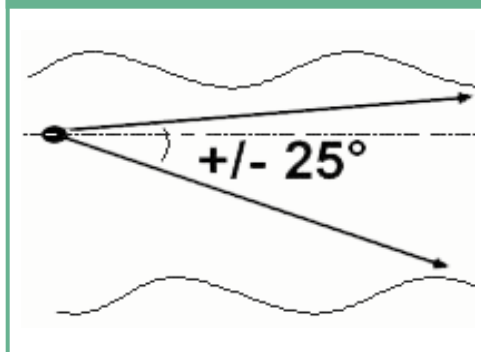

### WIRING

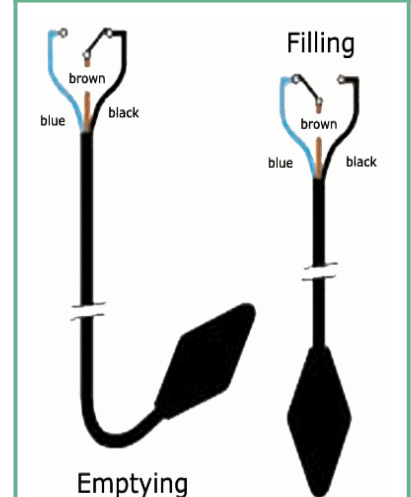

Please, refer to the connection diagram enclosed to each float delivered.

### APPLIANCES

For use in various liquids. Perfect for pumping stations, applications on building sites, waste water plants, industrial applications... and « ALARM » level detection.

### TECHNICAL CHARACTERISTICS

<b>Operation mode</b>	Omnidirectional
<b>Allowed fluid density</b>	0,70 a 1,15
<b>Maximum pressure</b>	3,5 bars
<b>Maximum temperature</b>	85°C
<b>Protection index</b>	IP 68 <input type="checkbox"/>
<b>Electric characteristics</b>	12, 24, 48 VAC/VCC and 250 VAC- 50/60 Hz
<b>Cut-out power</b>	16 (6) A (16 A resistive - 6 A inductive)
<b>Microswitch</b>	Silver / nickel reverser contacts
<b>Biconical shell</b>	Copolymer polypropylene
<b>Cable</b>	Neoprene or HR HY (hypalon) H07RN8-F
<b>Cable type</b>	3 conductors 1 mm <sup>2</sup>
<b>Float weight without cable</b>	200 g
<b>Cable weight</b>	Neoprene 115 g/m – HR HY 110 g/m
<b>Adjustable ballast on cable (series)</b>	Loaded resin 250 g
<b>Standard cable length (series)</b>	5, 6, 10, 13, 15, 20 and 25 m (other lengths on request)

